

# EXPLODED VIEW

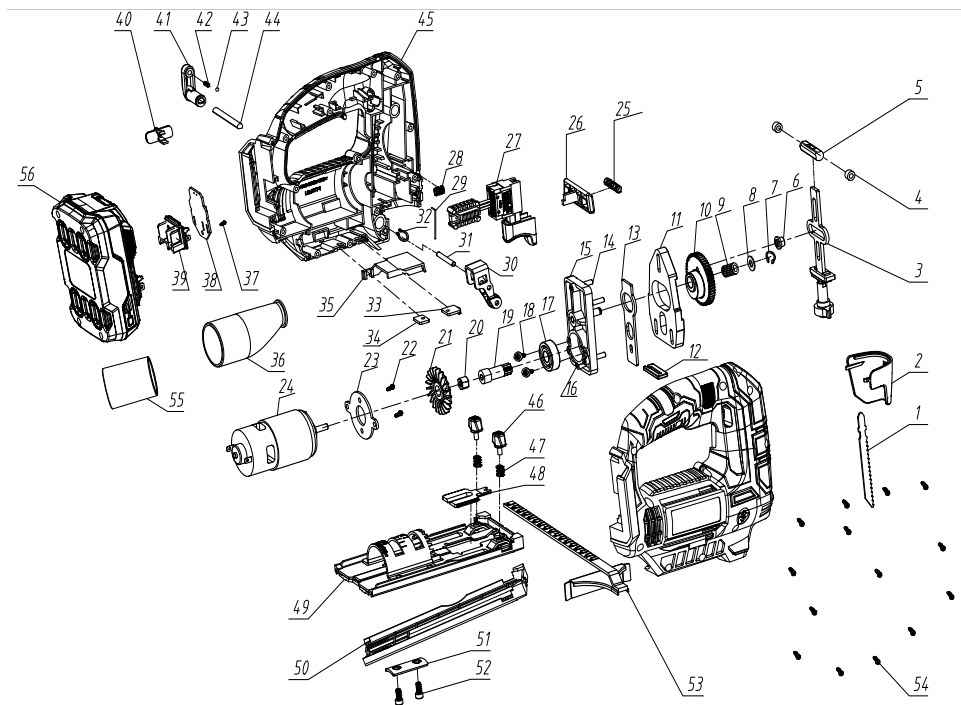

## SPARE PART LIST

PART NO.	DESCRIPTION	QUANTITY	
1	Wind Guard	1	0,06
2	Screw ST4.2x60	2	0,02
3	Stator	1	3,39
4	Housing	1	0,75
5	Right Rear Handle	1	0,75
6	Screw ST4.2x16	7	0,01
7	Screw ST4.2x14	6	0,01
8	Heat Insulation Plate	2	0,04
9	Screw ST2.9x10	4	0,01
10	Brush Holder	2	0,1
11	Electric Spring	2	0,08

12	Carbon Brush	2	0,26		
13	Front Cover	1	0,35		
14	Screw M4X28	2	0,01		
15	Spring for Blade Latch	1		0,04	
16	Movable Pin	1	0,04		
17	Reciprocating Pole	1	0,27		
18	Upper Guide Bushing	1		0,33	
19	Upper Guide Bushing Presser	1		0,01	
20	Spring Washer 4	10	0,01		
21	Screw M4x10	2	0,01		
22	Transmission Roller	1	0,22		
23	Needle Bearing	1	0,07		
24	Pin Ø5X15	1	0,03		
25	Transmission Wheel	1		0,91	
26	Balance Block	1	1,75		
27	Needle Bearing	1	0,23		
28	Wheel Gear	1	2,93		
29	Gear Washer Ø8.2×Φ14.5×0.5			2	0,01
30	Gear shaft	1	0,15		
31	Washer Φ12×Φ6.3×0.5	1		0,06	
32	Pin Ø4X24	3	0,03		
33	Screw ST4.2×25	2	0,01		
34	Pin Ø6X30	1	0,04		
35	Gear Box Assy	1	2,18		
36	Air Control Dial Button	1		0,04	
37	Iron cap	2	0,01		
	Circlip 4	2	0,01		
	Steel ball SΦ2.5	2	0,01		
38	Air Adjust Block	1	0,05		
39	Blower Seat	1	0,05		
40	Paper Washer	1	0,02		
41	Rectangular circle Φ26×Φ29×3			1	0,14
42	Bearing 6000	1	0,76		
43	Rotor	1	4,79		
44	Anti-dust Ring	1	0,01		
45	Flat Washer Φ4	2	0,01		
46	Blade Latch	1	0,14		
47	Blade Latch Wedge	1	0,01		
48	Screw ST4.2×65	2	0,02		
49	Transmission Box	1	1,06		
50	Lower Guide Bushing Spring	1		0,02	
51	Lower Guide Bushing Washer			1	0,03
52	Square Oil-proof Ring	1	0,02		
53	Square Oil-proof Ring Holder	1	0,02		
54	Lower Guide Bushing	1	0,62		